

Mitered Corner Dinner Napkins

1. Cut the napkin 20" for a generous size dinner napkin. If you prefer a smaller napkin cut the napkin to the desired size. Fold under a 1 inch hem along the four edges. Refold the hem for a 1/2" double hem.

Optional. For a perfect miter corner add 1/4" Steam a Seam II along the 1" fold line.

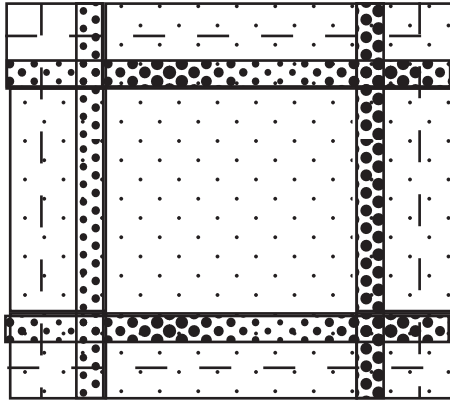

2. Fold the Napkin in half diagonally right sides together, making sure that the corner meets together evenly.

Turn your ruler at a 45 degree angle. Line it up to where the two corners intersect. Draw the diagonal line. Note: you can also fold on the straight edge of the fold for the same angle.

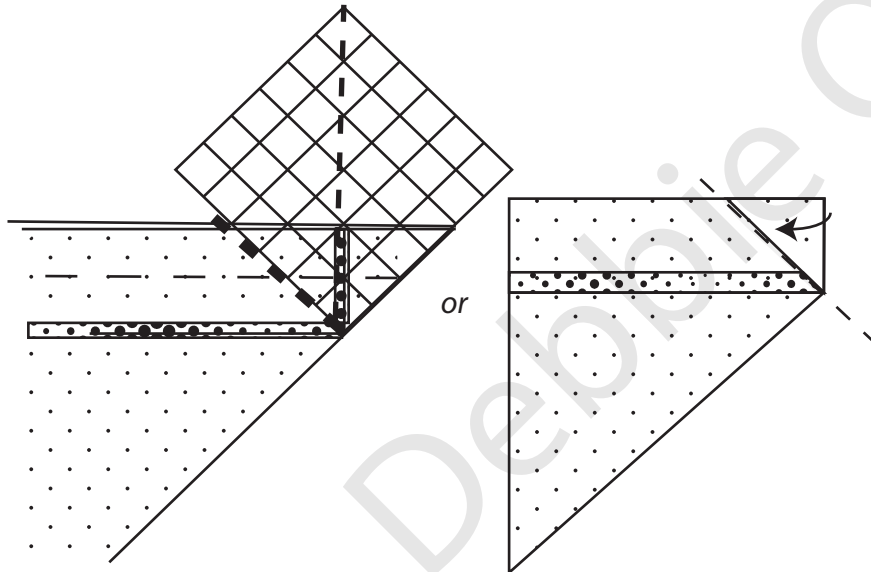

3. Marking Your Sewing Line

Intersect the ruler at the seam line for the right angle

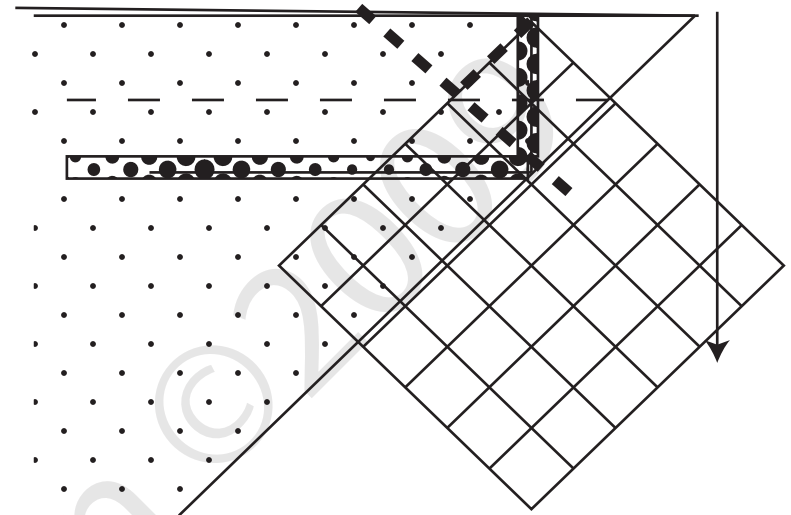

This is what your the corner that your are mitering should look like now.

Pin together and sew along the marked line

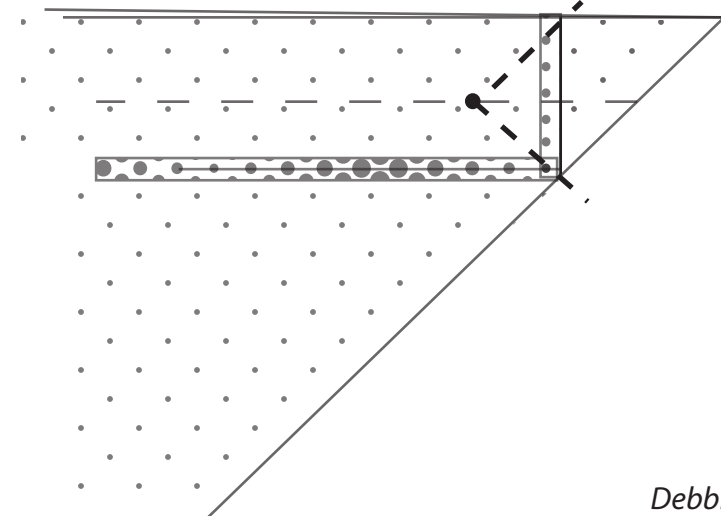

Mitered Corner Dinner Napkins

4. After Sewing your Corner trim the seam allowance and clip to intersection being careful not to clip through your stitching. Repeat for all four corners.

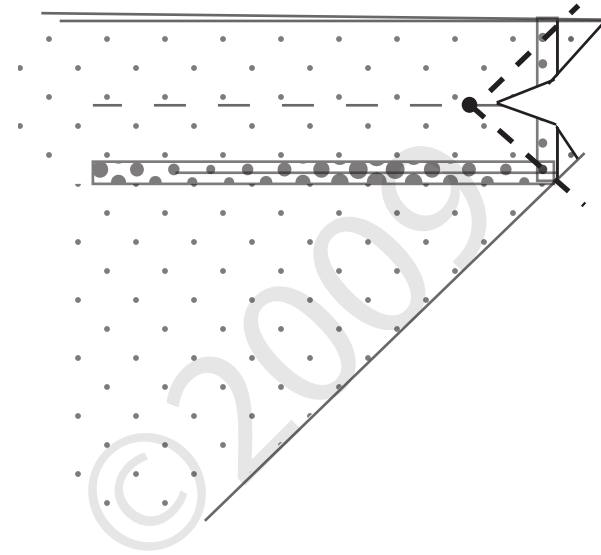

Turn the napkin right sides out and fold in your hemmed edges. Use a point turner at each mitered corner if necessary being careful not to poke the turner through your stitching. Press.

If you used the optional Steam A Seam II Peel the paper backing after turning the edges under and press.

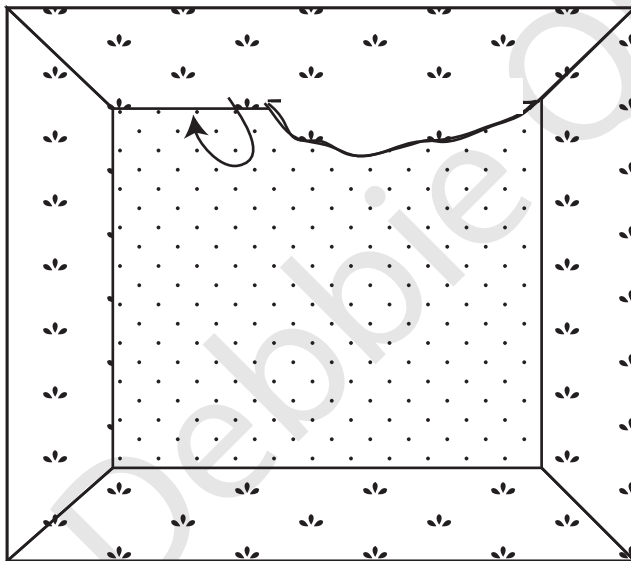

Press and fold along the 1" mark. Then turn under the edge 1/2" in.

6. From The right side-Top Stitch around the perimeter 3/8" from the edge of the napkin.

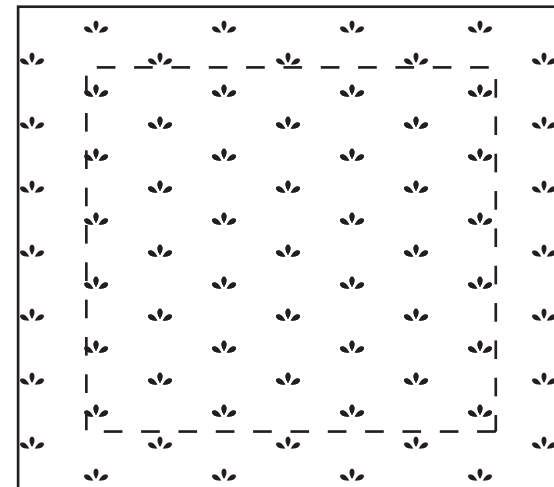

Debbie Quinn
©2009